

DMP Work Shop in Osaka, 2004/07/12

Standardization of New Broadcasting System and Its Service Scenarios

July 12, 2004

Keigo Majima

Science & Technical Research Laboratories

NHK

majima.k-fu@nhk.or.jp

Outlines

A thick, horizontal yellow brushstroke is positioned below the title, extending across most of the width of the slide.

1. Digital Broadcasting in Japan
2. Standardization of Broadcasting System
Based on Home Servers in Japan
3. Service Scenarios on The New Broadcasting
4. Overview of the RMP System
 - Advanced Conditional Access System

Digital Broadcasting in Japan

- Digital satellite television broadcasting started in December 2000.
- Digital terrestrial broadcasting has begun in the three major metropolitan areas of Tokyo, Osaka, and Nagoya in December 2003.
- The government's plan describes a schedule for broadcasting to have started in all major cities by the end of 2006.
- These new form of broadcasting bring transformation in Japanese Broadcasting: digital technology will lead to new function and interactivity for television.

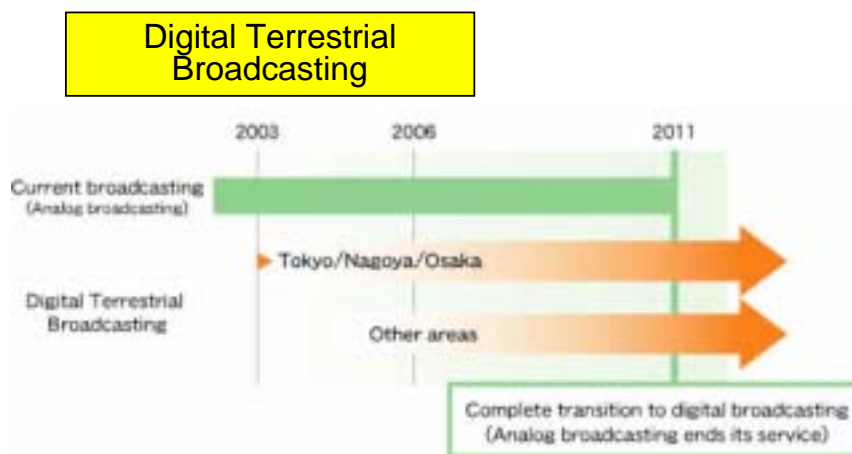
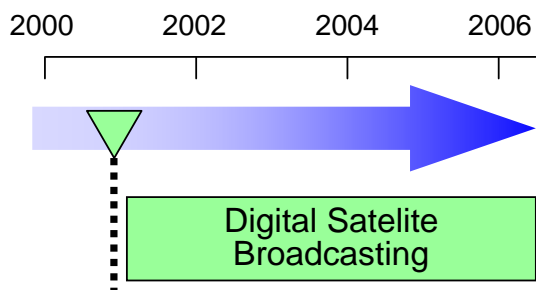

Digital Terrestrial Television Broadcasting

Characteristics

- High-quality audio-visual services featuring HDTV.
- Various forms of data broadcasting (national and local services).
- Motion picture services for portable terminals.
- Multi-view broadcasting that will implement multi-channel services for standard picture TV broadcasting.
- High-quality video services without "ghost interference" (doubling of TV images), or noise.

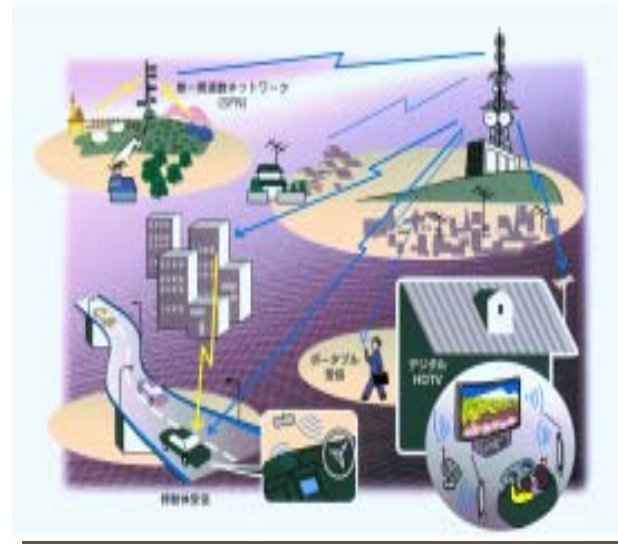

Growing Expectations for New Broadcasting

In November 1998, NHK conducted a survey on the needs for new television services. As the results, people want anytime news and weather information the most, followed by anytime programs and movies, indicating that viewer expectations are growing for the early realization of home servers, which provide “anytime” functions.

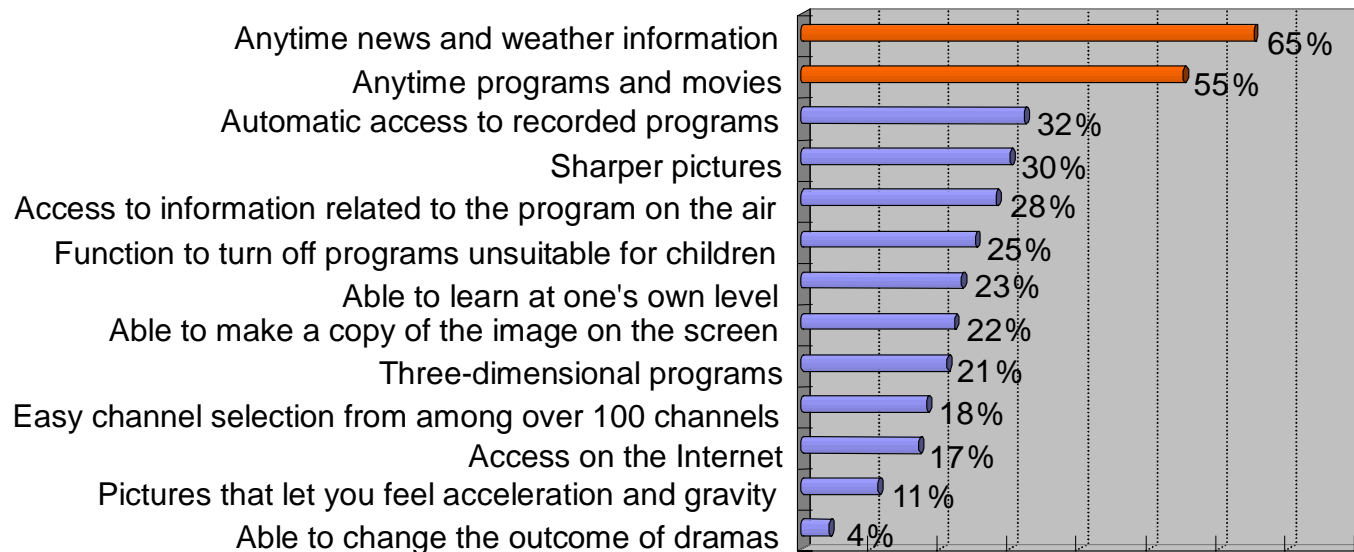

Source: Survey by NHK Broadcasting Culture Research Institute (the survey covered a total of 2,892 people aged 16 or older in Japan in November 1998.)

Broadcasting System based on Home Server

A broadcasting system based on home servers utilizes a receiver equipped with **high-capacity storage function** and **communication network function**. The broadcasting service for the Server-Based Receivers is called "Broadcasting Service based on Home Servers".

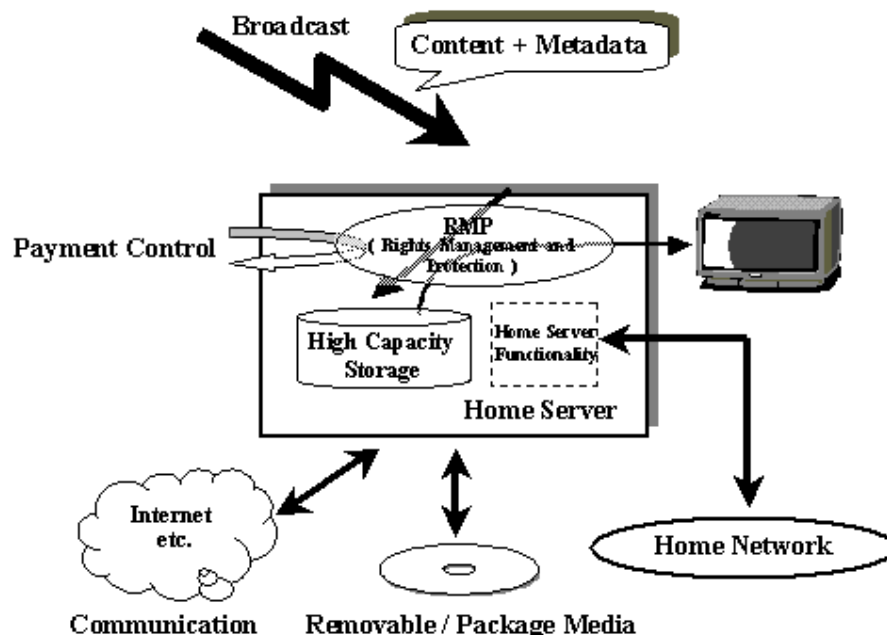

Broadcasting Service based on Home Server

A broadcasting system based on home servers will promote diverse TV viewing styles, such as viewing programs at exactly the preferred time or retrieving only pieces of programs, by using metadata provided by the broadcaster.

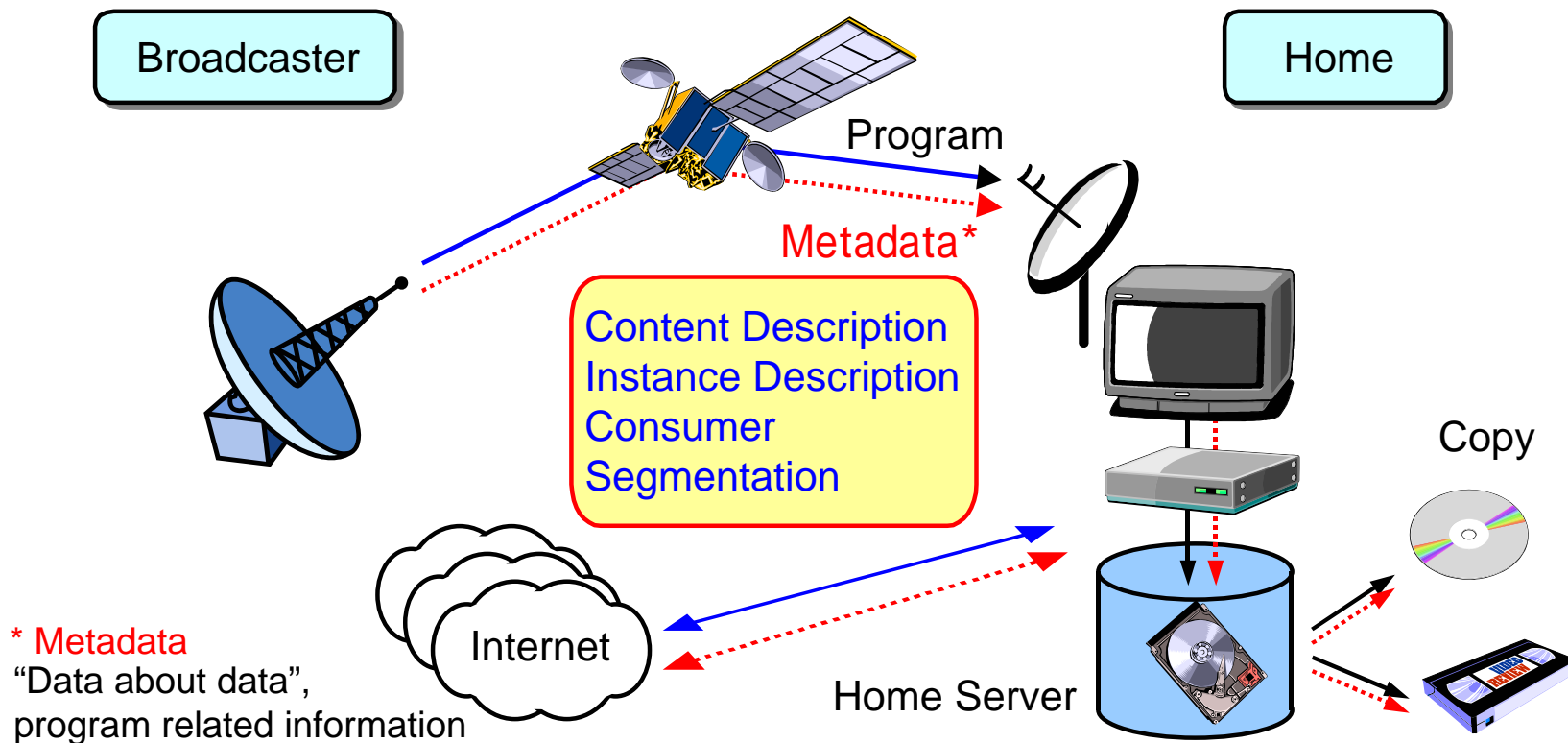

Standardization of New Broadcasting System (1)

Objective

Development and standardization of production, query, storage and delivery systems suitable for services with respect to the new broadcasting system based on Home Servers.

System Scope

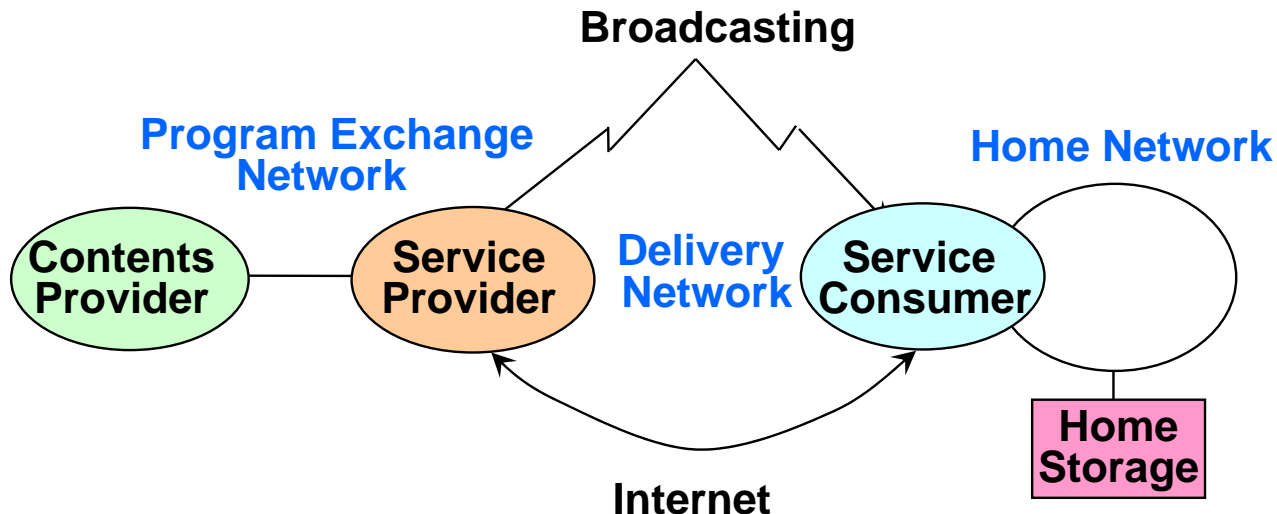

Standardization of New Broadcasting System (2)

Concepts behind standardization

- Ability to secure continuity and matching with the conventional broadcasting system so that there is no contradiction between existing broadcasting services and broadcasting services based on home servers.
- Ability to secure the diversity of the services and flexibility for future expansion of broadcasting based on home servers.
- Ability to protect the rights of content and ensure security for steady development of the contents industry.
- Need to maximize compatibility with international standards so as to facilitate the distribution of contents and reduce the price of equipment.

Standardization of New Broadcasting System (3)

Standardization of broadcasting system for new television broadcasting services

In October 1999, ARIB* set up a WG to develop and standardize a broadcasting system based on home servers. It works closely with the TV Anytime Forum to coordinate international standardization work. In February 2003, ARIB **STD-B38** has been established.

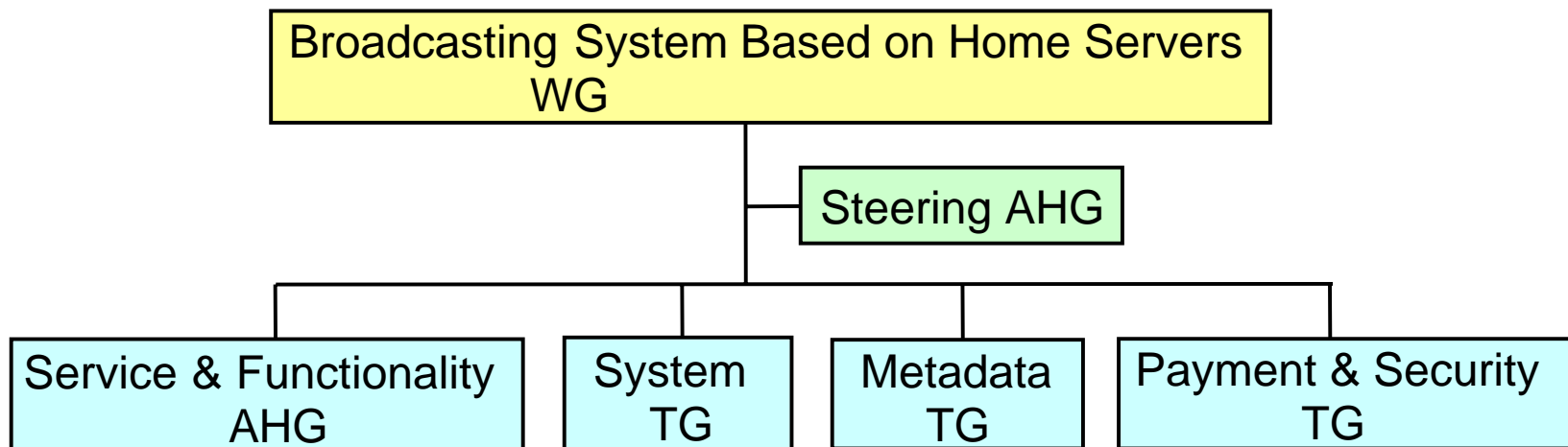

* ARIB: Association of Radio Industries and Businesses

Service Scenarios on The New Broadcasting (1)

Digital Terrestrial Broadcasting for Mobile & Portable Receivers

In the near future (by March, 2006), digital terrestrial broadcasting will be receivable on cellular phones or portable TV receivers. For this kind of reception, we are studying new network-linked data broadcast services that combine narrow-band broadcasting and information through a communications network.

Digital terrestrial broadcasting

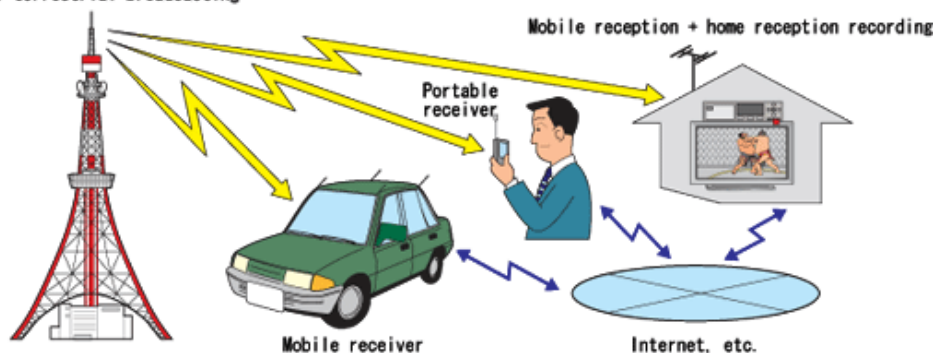

Service Scenarios on The New Broadcasting (2)

Broadcasting Services Based on Home Servers

- Storage/reception of broadcast contents, and new services combined with the Internet links
 - Using broadcast programs and program-related contents via the Internet
 - combining contents seamlessly from broadcasts, communications, and home servers using metadata
 - Protecting content copyrights using advanced CAS (Super CAS)
- TVs will become in-home integrated services television that combine broadcasts and communications.

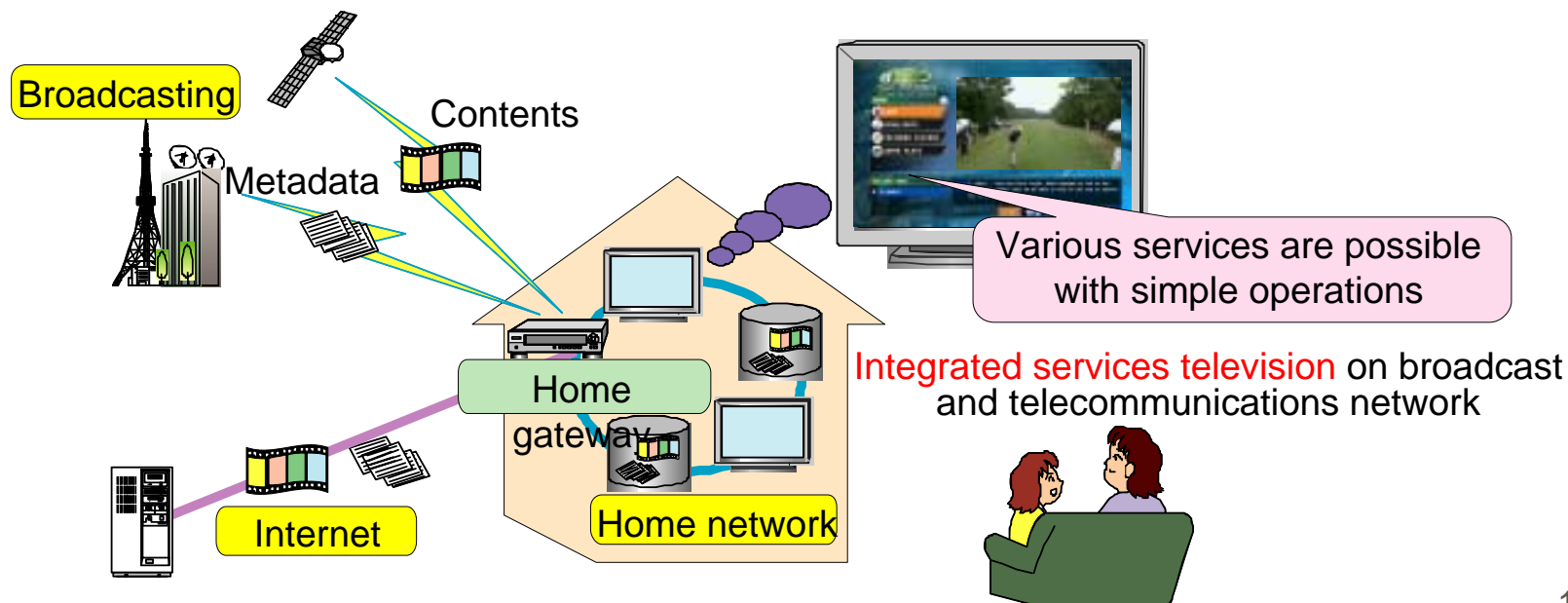

Service Scenarios on The New Broadcasting (3)

Integrated Services Television

In the near future, the TV, as “ the most familiar” medium, will likely develop into a gateway to the information society. Digital television could become indispensable as a medium providing new services that link broadcasting and the Internet.

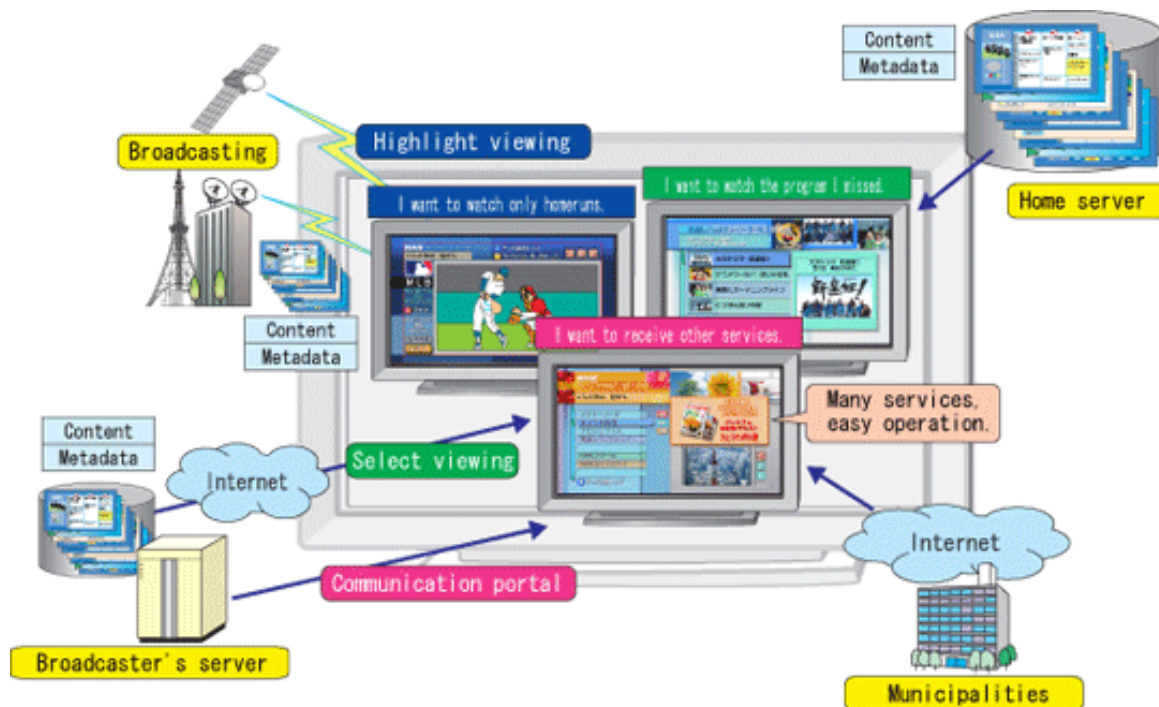

Service Scenarios on The New Broadcasting (4)

Content and Metadata distribution model

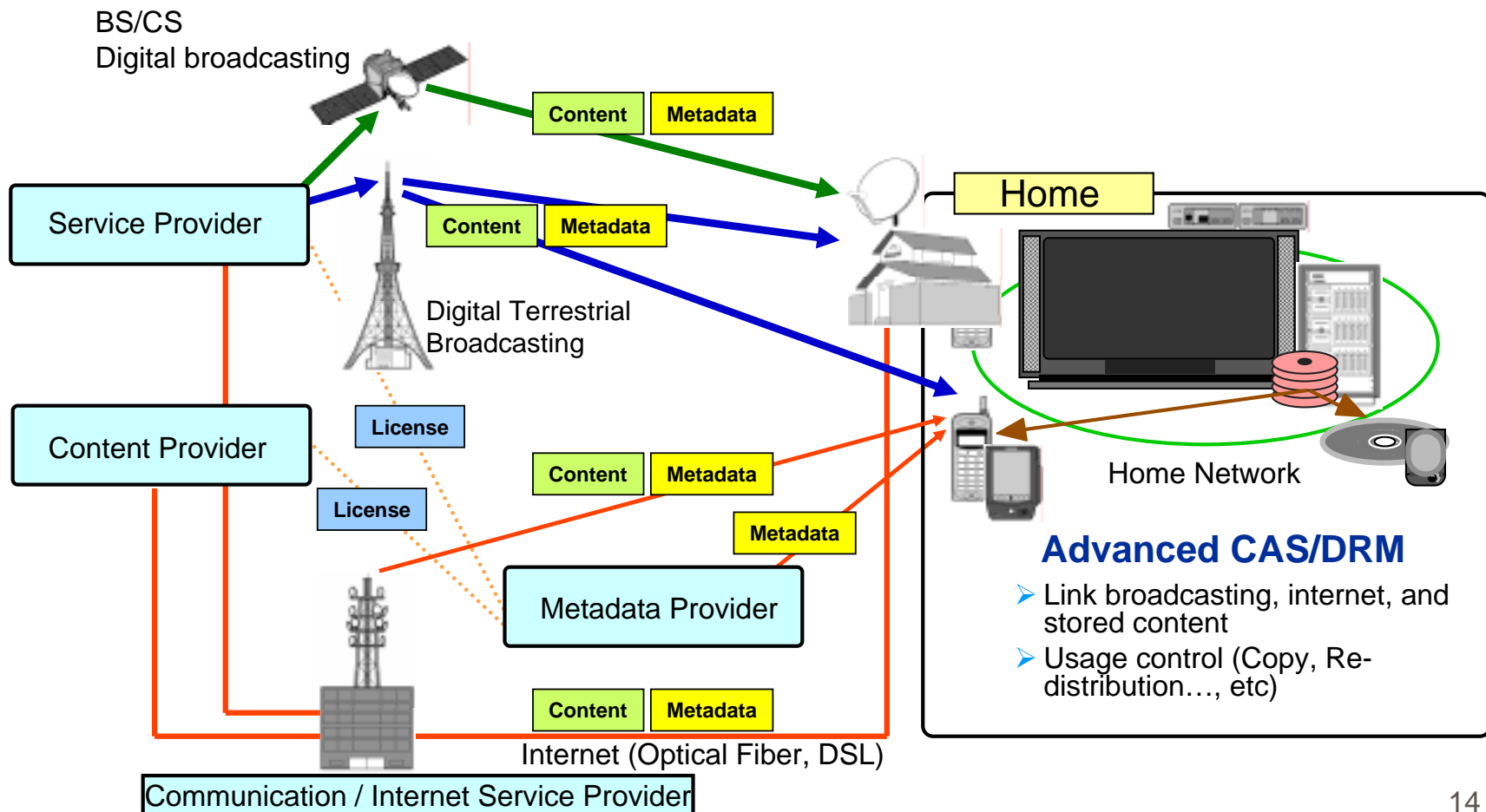

Introduction of RMP System

- Advanced Conditional Access System (CAS)

While a broadcasting system based on home servers will offer a wide range of TV viewing styles by using metadata, it also requires a mechanism for content usage control as designated by the broadcaster.

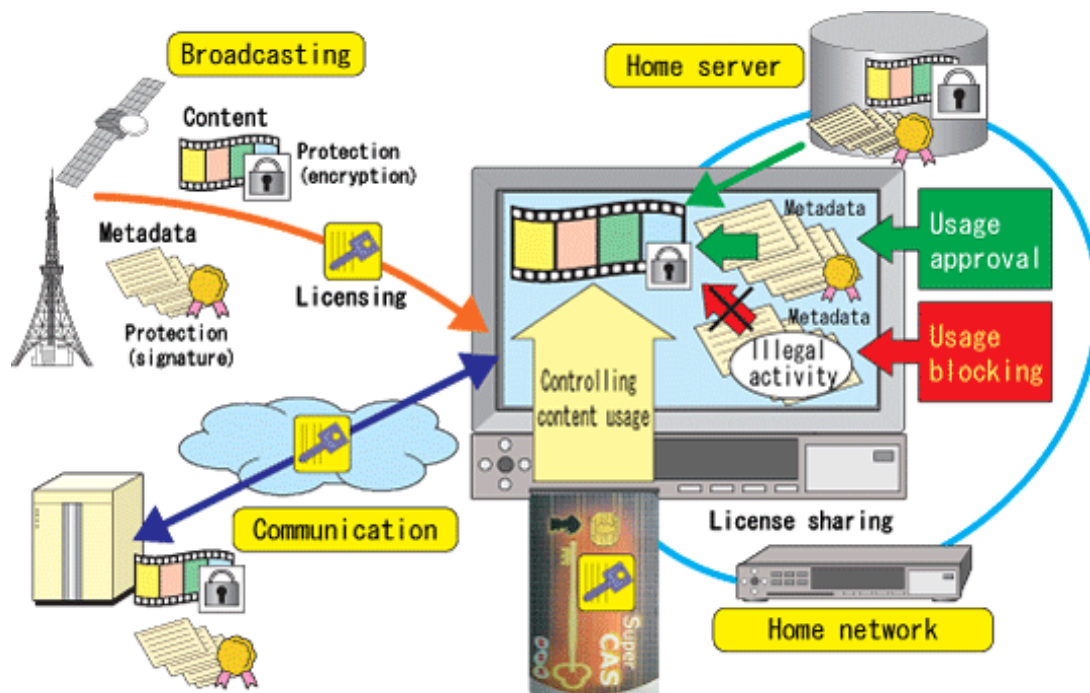

Overview of Advanced CAS

An advanced CAS performs viewing control and content rights protection.

Features

- With a single CAS card, it achieves low-cost content rights protection as well as viewing control for the content distributed via the Internet and stored content.
- The broadcaster can set up detailed control conditions in relation to digital content usage.
- The licensing information required for viewing a program can be acquired via broadcasting or the Internet.
 - Ex. When the viewer wishes to watch expired content, he or she can obtain a license with a new expiration date.
- This technology enables a secure environment for content and metadata by preventing tampering, ensuring that only metadata approved by the broadcaster can be utilized.

Evolution of RMP System

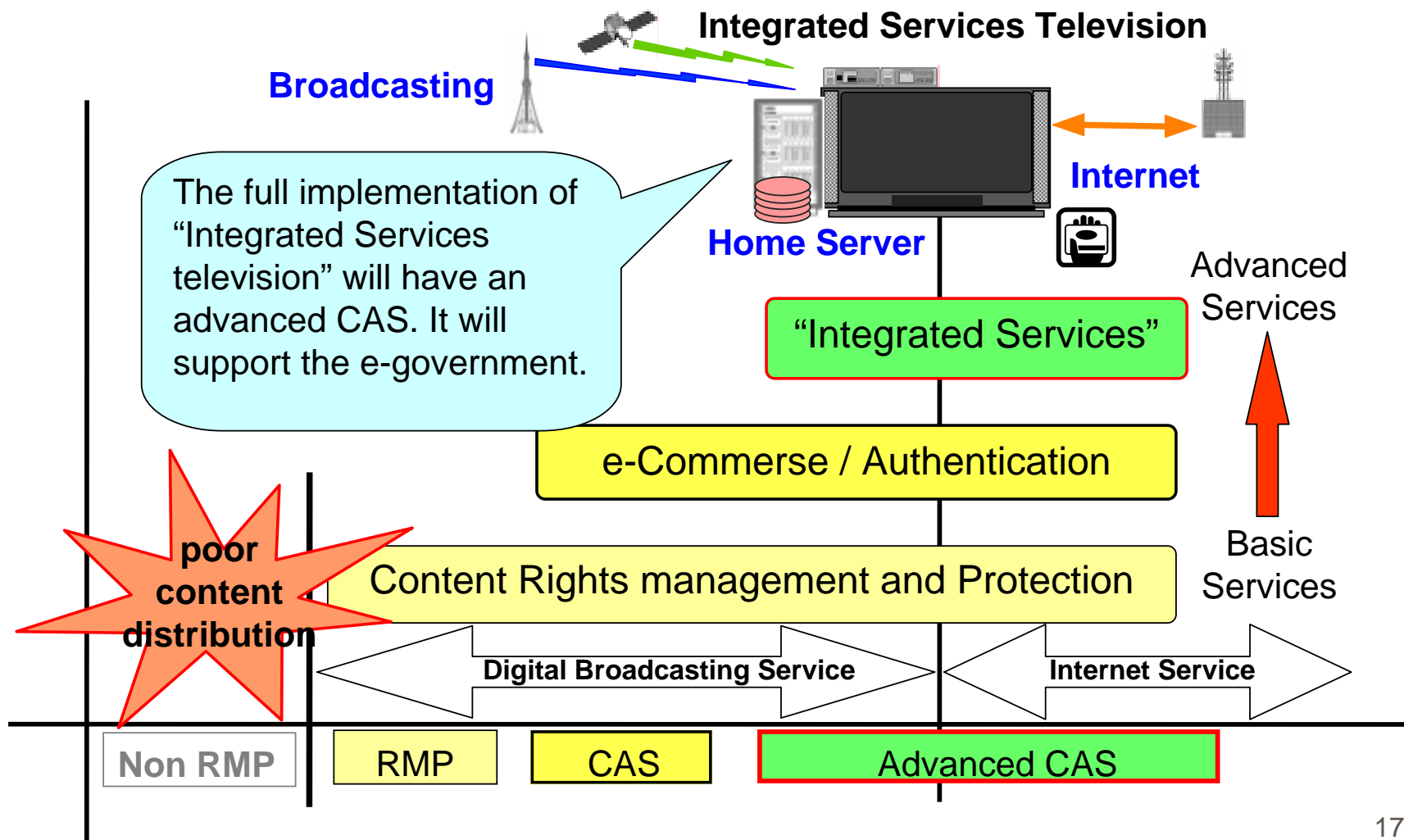

Summary

- Digital terrestrial broadcasting has started in Japan, and it provides diverse services.
- Standards of broadcasting system based on home servers has been established, which enables the diversity of the services and flexibility for future expansion.
- The TV of the future will be positioned as an “Integrated services television” for the home that promotes rich broadcasting content distribution.
- Advanced CAS (Conditional Access System) is the key for the services on the new broadcasting system.